Installation Guide

Publication number E5315-92006
March 1996

For Safety information, Warranties, and Regulatory
information see the pages behind the index.

© Copyright Hewlett-Packard Company 1994-1996
All Rights Reserved

PQFP Adapter

Your PQFP Adapter — At a Glance

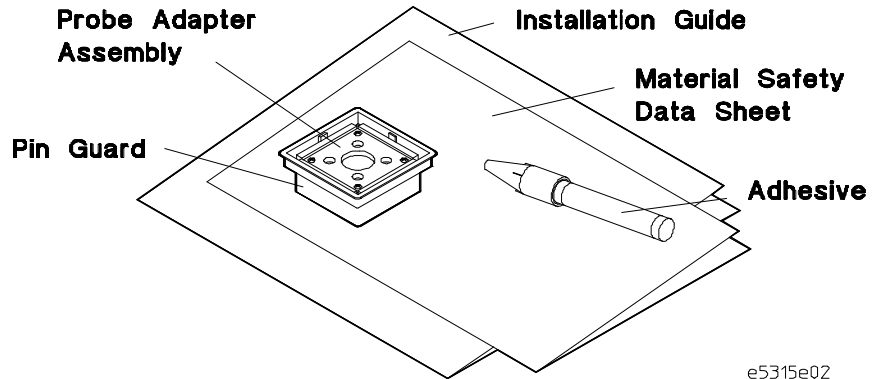

This Installation Guide provides instructions for using Hewlett-Packard's advanced probing system for 0.5-mm pitch Plastic Quad Flat Pack (PQFP) and Ceramic Quad Flat Pack (CQFP) surface-mounted integrated circuits. This probing system provides a quick and reliable connection from these devices to Hewlett-Packard oscilloscopes, logic analyzers, and emulators.

This information shows you how to use the PQFP Adapter, and also includes optional accessories that will enhance the adapter's use in particular probing situations. Drawings are also included that instruct you in laying out printed circuit boards with the proper component spacing to correctly use the adapter.

	160-, 184-, 208-, 240-Pin	304-Pin
Electrical Characteristics		
Operating Voltage	< 40 V (dc + Peak ac)	< 40 V (dc + Peak ac)
Operating Current	0.5 Amps Maximum	0.5 Amps Maximum
Insulation Resistance	> 100 M Ω	> 100 MW
Model Parameters		
Capacitance between Contacts	2 pF (Typical)	2.5 pF (Typical)
Self-Inductance	30 nH (Typical)	45 nH (Typical)
Contact Resistance	< 0.1 Ω	< 0.1 Ω
Operating Bandwidth	dc - 600 MHz	dc - 500 MHz
Environmental Characteristics		
Operating Temperature	0 °C to 50 °C	0 °C to 50 °C
Relative Humidity	75% Maximum	75% Maximum

Tools Needed for Installation

Sandpaper, 600-grit
 Flux remover/degreaser
 Isopropyl Alcohol
 Lint-free cloth
 Round toothpick
 Magnifying glass or microscope
 Dags/tweezers
 Screwdriver, #1 Posi-Drive
 Light (flash light)
 Tissue
 Soldering iron
 Solder, 63/37 rosin core

Prepare the target IC

WARNING

Flux remover use has hazards. Read the instructions accompanying the flux remover and carefully follow the manufacturer's directions in its use. The use of flux remover in the work place may legally require that a Material Safety Data sheet for flux remover be available.

CAUTION

Power off the target IC before cleaning it and installing the probe adapter.

Use grounded wrist straps and mats when preparing the target IC. Electrostatic discharge can damage electronic components.

Overly aggressive use of this cleaning procedure can result in damage or contamination of the target IC and/or adjacent components.

- 1** Inspect each lead of the target IC, using a microscope if available, to assess the degree of cleaning needed to remove flux or debris.
 - Remove thin oxide layers with mild sanding.
Thin oxide layers may be transparent, but still interfere with probe operation.
 - Use more aggressive sanding to remove flux layers or other coatings.
 - Remove loose particles with precision dusting cleaner (also known as inert dusting gas or compressed air in a can).
- 2** Wet each lead of the target IC with flux remover, then blow dry with precision dusting cleaner (also known as inert dusting gas or compressed air in a can).
- 3** Using a one-inch-square piece of 600-grit sandpaper, folded with the sand side out, rub the target IC leads until they appear clean and shiny.
- 4** Again, wet each target IC lead with flux remover and blow dry with precision dusting cleaner (also known as inert dusting gas or compressed air in a can).
- 5** Inspect each lead of the target IC to assess whether the cleaning procedure should be repeated.

Prepare the adapter assembly

1 Remove the pin guard.

CAUTION

Put the pin guard back on the probe adapter when not in use. Touching the ends of the adapter wires will contaminate them and destroy the electrical contacts. Bent adapter wires will prevent proper alignment with the package legs.

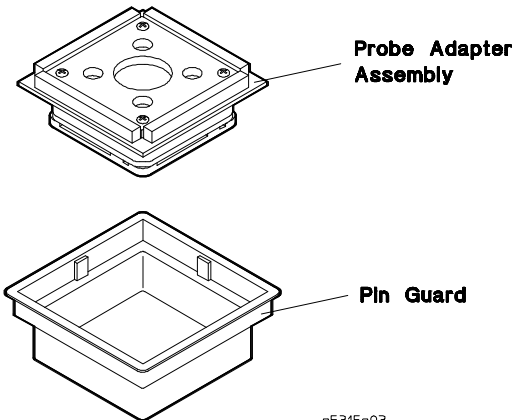

2 Unscrew the four screws and remove the locator base.

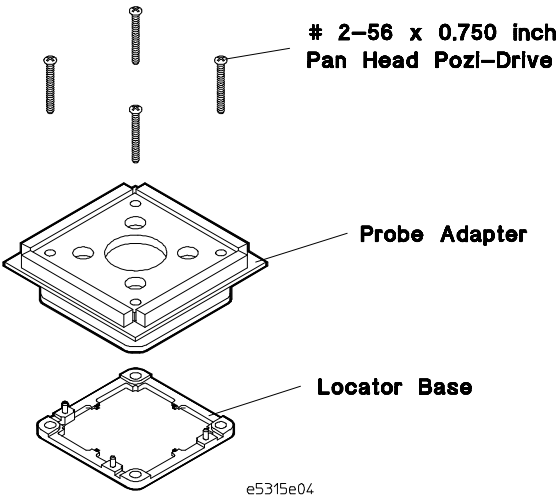

3 Clean the probe adapter.

CAUTION

Overly aggressive use of this cleaning procedure can result in damage or contamination of the probe adapter.

- a Inspect each pin of the probe adapter, using a microscope if available, to assess the degree of cleaning needed to remove surface films or debris.
 - Remove loose particles with precision dusting cleaner (also known as inert dusting gas or compressed air in a can).

WARNING

Isopropyl Alcohol use has hazards. Read the instructions accompanying the Isopropyl Alcohol and carefully follow the manufacturer's directions in its use.

The use of Isopropyl Alcohol in the work place may legally require that a Material Safety Data sheet for Isopropyl Alcohol be available.

- b Wrap a one-inch-square piece of lint-free cloth around a toothpick and wet the cloth with alcohol.

CAUTION

Any contact with the gold-plated pins of the probe adapter can abrade the gold plating. This can cause permanent damage to the probe or expose the underlying surface which will enable oxidation in humid environments. Hewlett Packard defines "delicately rubbing the pins" as being equal to holding a pen between two fingers without enough pressure to lift it.

- c Delicately rub the lint-free cloth against each probe pin at the point of contact with the target IC leads.
- d Blow dry the probe pins with ambient-temperature, high-pressure air.
- e Inspect each pin of the probe. Each pin should display a shiny gold surface.

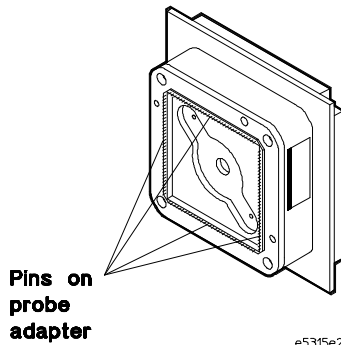

Attach the locator base

1 Check the area around the package to be probed.

The probe will work within the parameters shown in figures 1 through 4. Any dimensions outside of this window may require special adjustments in probe positioning for it to be operational.

CAUTION

Use grounded wrist straps and mats when installing or performing any service to your probe adapter. Electrostatic discharge can damage electronic components.

Figure 1. 160-Pin Adapter Parameters

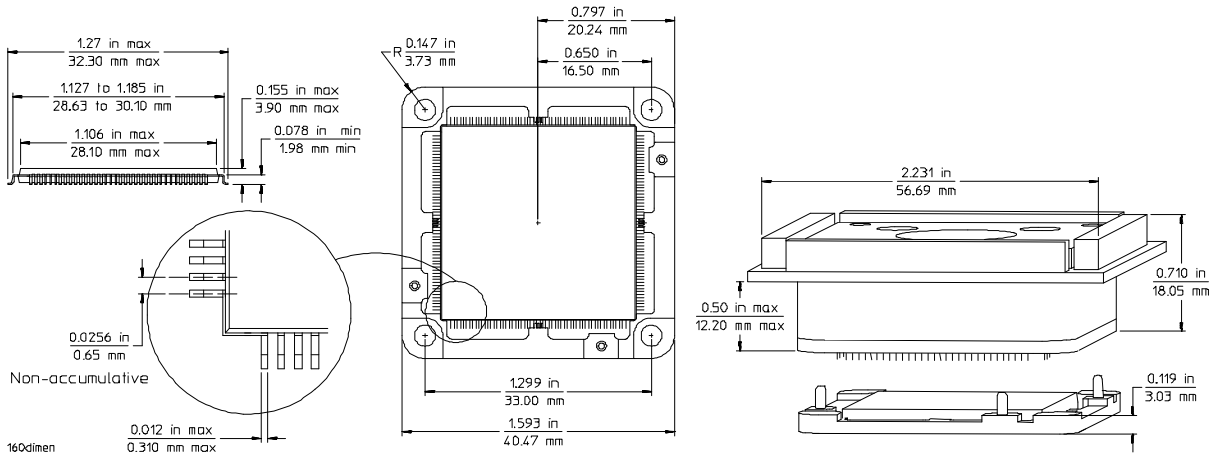

Figure 2. 184-Pin Adapter Parameters

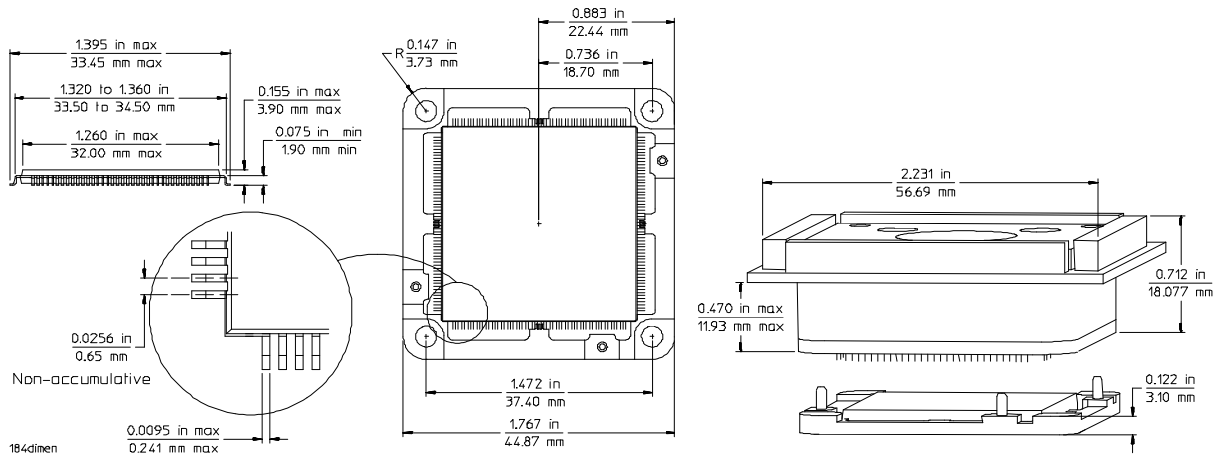

Figure 3. 208-Pin Adapter Parameters

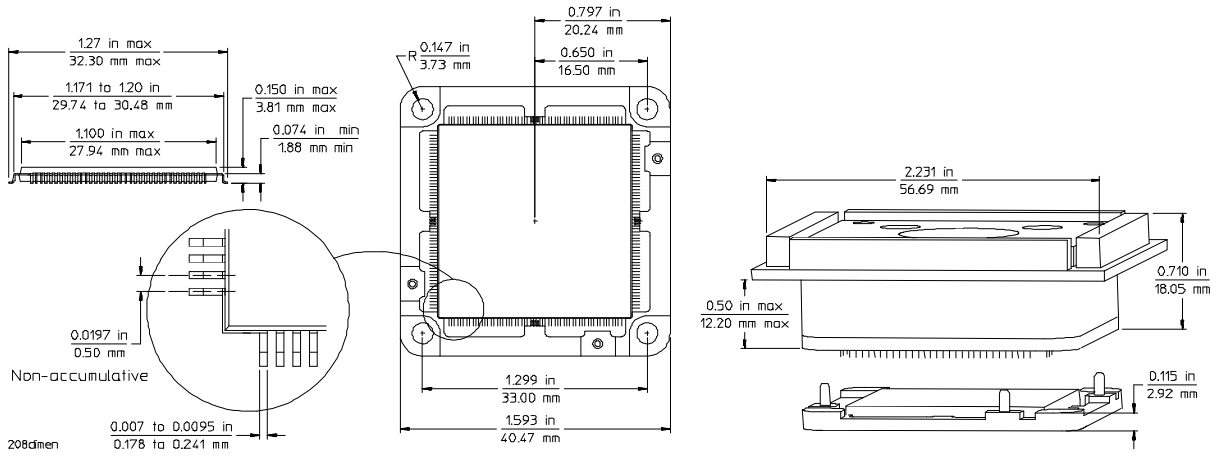

Figure 4. 240-Pin Adapter Parameters

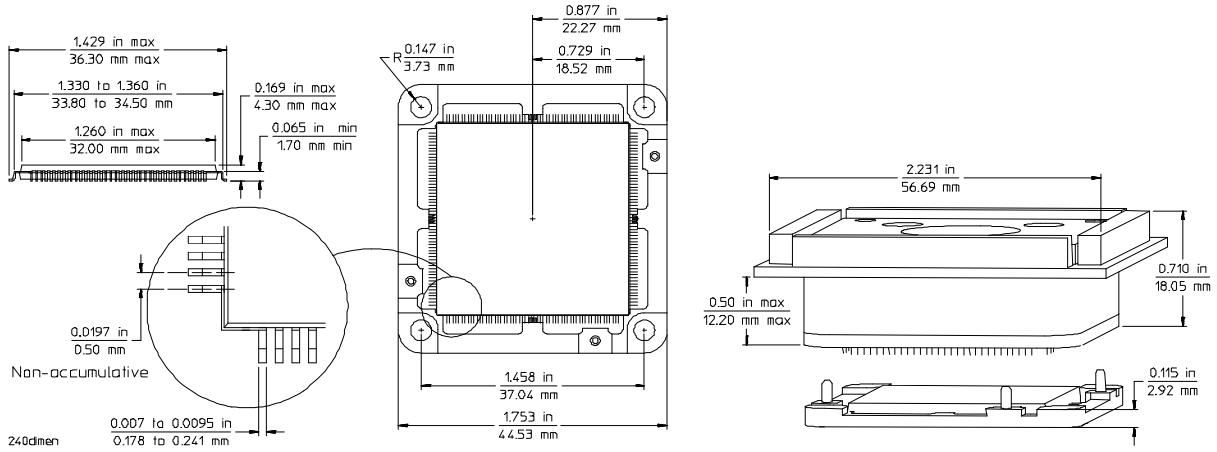
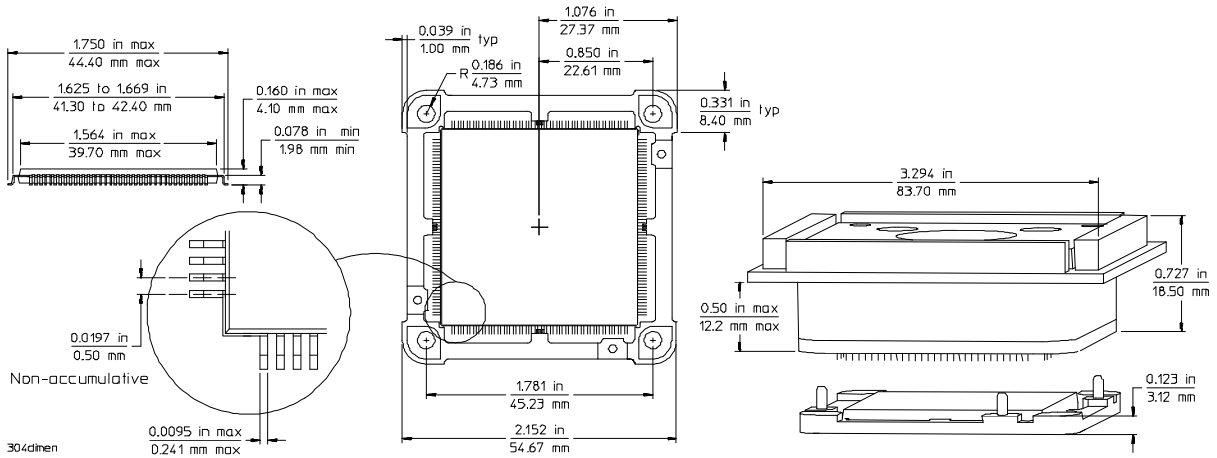

Figure 5. 304-Pin Adapter Parameters



Attach the locator base

2 Use the locator base provided or mount inserts on your PC board.

- If you are using the locator base provided, it has inserts mounted in the corners for use on PC boards that do not have mounting holes designed to accept a locator base. For probing additional ICs, refer to "Additional Parts" later in this document for locator kit part numbers.

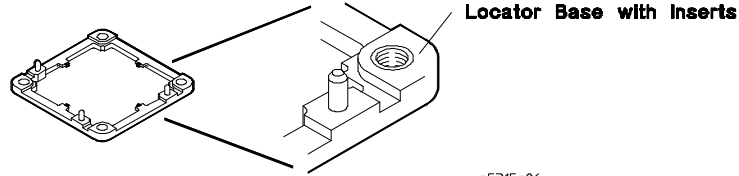

- If you are mounting inserts on your PC board, use an external mount kit which has a locator base without inserts and longer screws. Refer to table 1 for external mount kit part numbers. Refer to figures 1 through 4 for layout dimensions to mount four #2-56 inserts on your PC board.

After mounting the locator base, go to "Establish the Grounding" later in this document. The locator base without inserts does not need to be glued down.

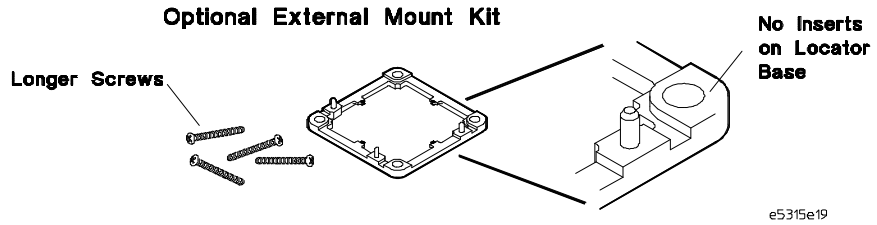

Table 1

Optional External Mount Kits

HP Prod/Part #	Use With
5042-1707	160-Pin Adapter
5042-1731	184-Pin Adapter
5042-1702	208-Pin Adapter
5041-9490	240-Pin Adapter
5052-1717	304-Pin Adapter

3 Test the alignment before adhering the locator base.**CAUTION**

Installation of the locator base to the PC board is considered PERMANENT. Any attempt to remove the IC, locator base, or the PC board may result in damage to all three parts.

- a Remove any flash at the corners of the IC or between pins. An excess of flash will inhibit the locator base seating on the board.
- b Align the color band on the locator base with the Pin 1 corner or Pin 1 side of your package.
- c Place the locator base on the package to be probed to see that it can be located properly. The combed guides on all four sides must be centered on the package sides and the base must be seated on the board.

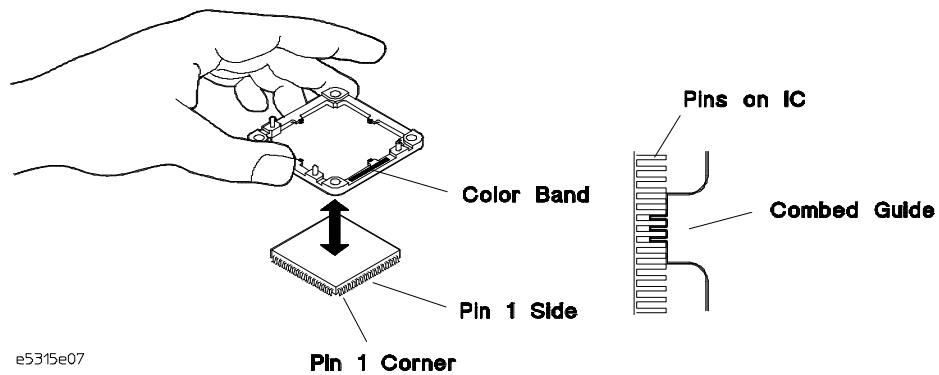

e5315e07

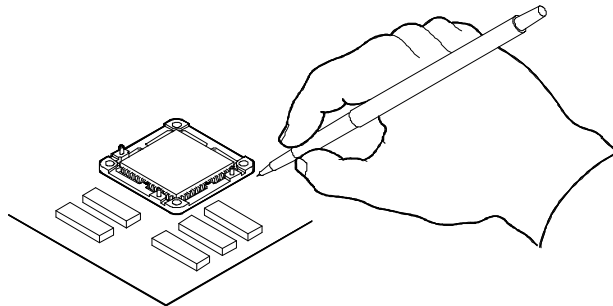
4 Outline the locator base to use as a guide for applying the adhesive.

e5315e09

5 Remove the locator base.

Attach the locator base

- 5 Apply adhesive to your PC board. Follow the manufacturer's recommended temperature parameters for the adhesive in the enclosed Material Safety Data Sheet.

WARNING

Read the Material Safety Data Sheet enclosed for handling precautions on the Loctite Superbond495 or call Loctite Corporation at (203) 571-5100.

Loctite Instant Adhesives are non toxic. The vapors can cause eye irritation in poorly ventilated areas or low-humidity environments.

Accidental skin bonding is best handled by passive, non surgical first aid. Hot soapy water aids separation of skin tissue. Use peeling, not pulling action to separate bonded tissue.

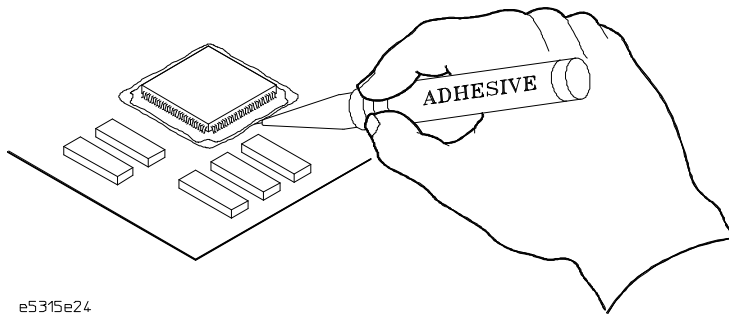

e5315e24

- 6 Place the locator base on the package to be probed, and apply downward pressure to ensure that the locator base adheres to the PC board. Allow the adhesive to set at least 10 minutes before attaching the probe adapter.

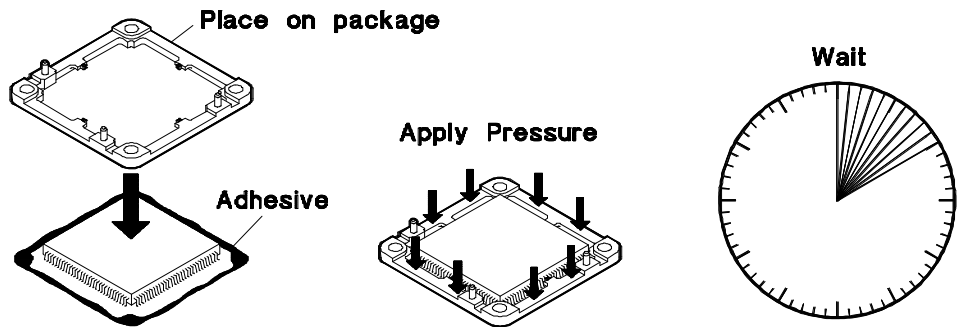

e5315e15

Establish the grounding

Establish the grounding before the probe adapter is installed on the locator base. The ground plane of the probe adapter is common to the ground ring on the under side of the PC board mounted on top of the probe adapter. You can tie this ground ring to any ground reference on the package.

When probing an address bus, a data bus, or control lines, you must return the probing currents back to the PQFP via the ground pins that are physically near these probe points. Typically, there is a ground pin for every five to eight other pins.

For example, one side of a 240-pin PQFP may have eight to ten ground pins. When using the probe adapter, you must tie the probe adapter ground ring to the PQFP ground pins on the side of the package that is being probed. If all the pins are being probed, you should attempt to tie all the ground pins on that side to the probe adapter ground ring. A good rule of thumb is to tie one ground pin for every four or five probes that are attached.

- 1** Refer to the data sheet for your PQFP to determine which pins will be used as grounds. A diagram of the top view of the PQFP chip is on the following page.
- 2** Translate the PQFP pin numbers to the pin numbers of the socket on the top of the adapter. See the diagram of the top view of the sockets on the following page.
- 3** Translate the socket pin numbers to the socket legs underneath the adapter. The socket leg numbers are printed on the PC by the socket legs.

Top View of Sockets on Probe Adapter Assembly

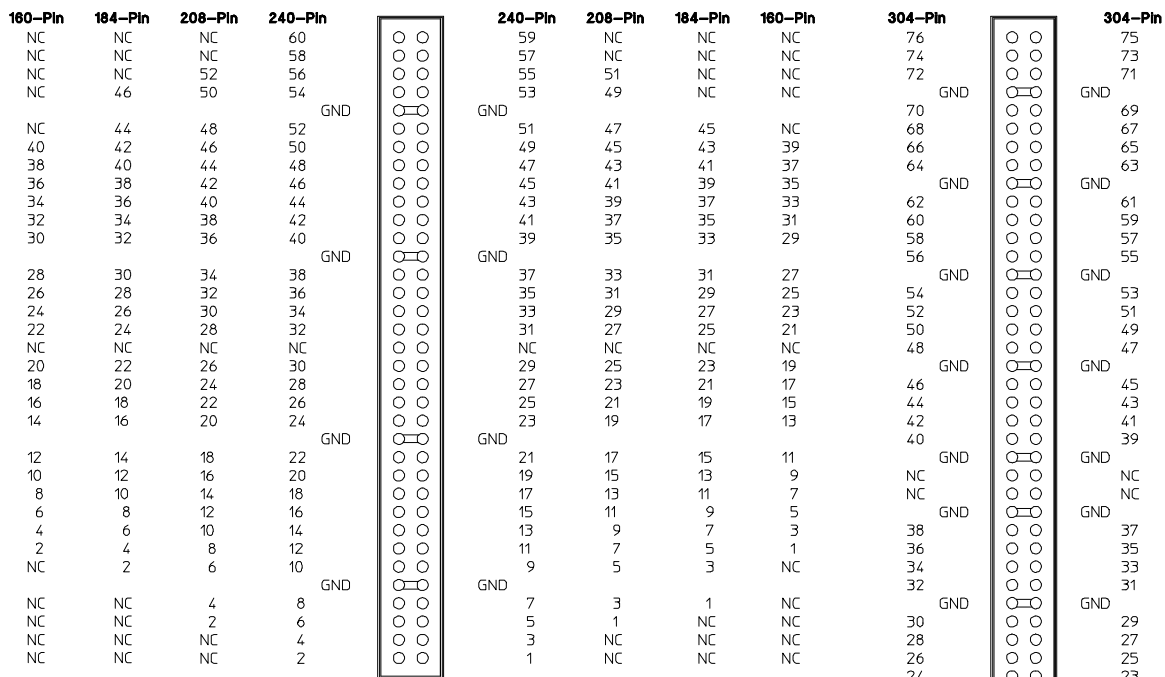

70-Pin Connector, 0.05 in x 0.05 in

Top View of PQFP Chips

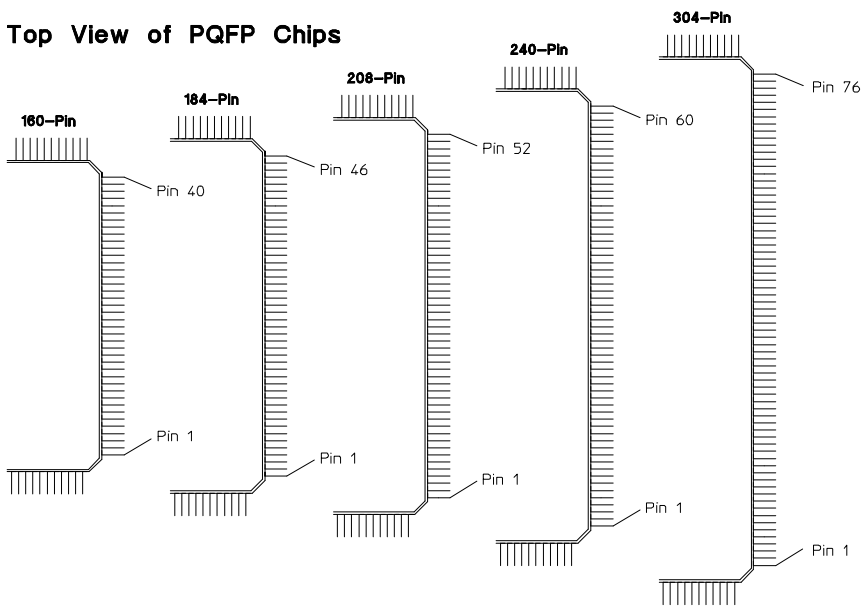

100-Pin Connector, 0.05 in x 0.05 in

4 Bend and solder the socket legs to the ground ring.

- a** Bend the socket legs down to touch the ground ring, then solder them.

The 304-pin adapter has ground rings on the inside and outside. The 160-, 184-, 208-, and 240-pin adapters have a ground ring on the outside only. If you have a 160-, 184-, 208-, or 240-pin adapter, use as many of the outside legs as possible.

- b** If you still need more grounds on your 160-, 184-, 208-, or 240-pin adapter, solder a fine wire to the ground ring and then to the leg to be grounded. Allow enough length in the wire so that it can be kept away from adjacent legs that might cause it to short.

CAUTION

Handle the probe adapter carefully. Any contact with the gold-plated pins of the probe adapter can abrade the gold plating. This can cause permanent damage to the probe or expose the underlying surface which will enable oxidation in humid environments.

160-, 184-, 208-, and 240-Pin

304-Pin

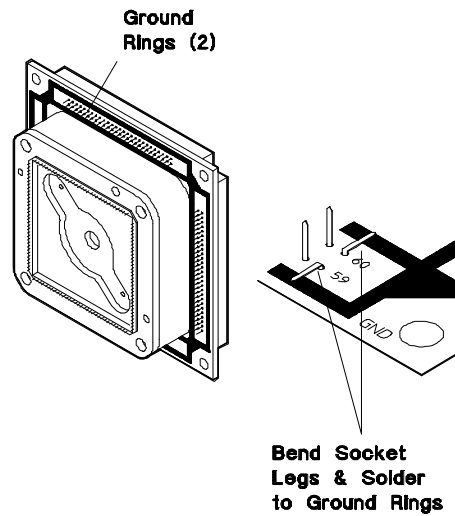
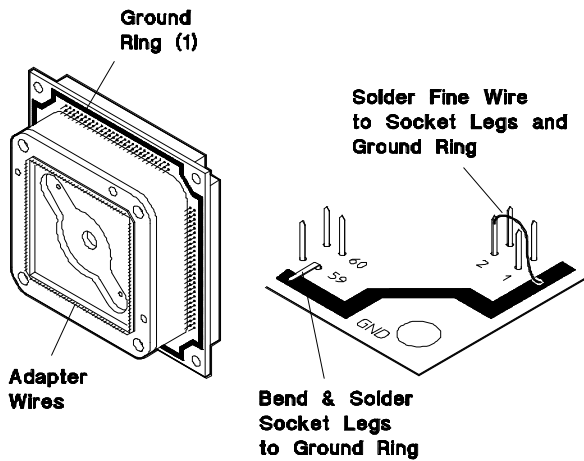

e5315e14

Install the probe adapter

- 1 Align the yellow band on your probe adapter with the one on the locator base.

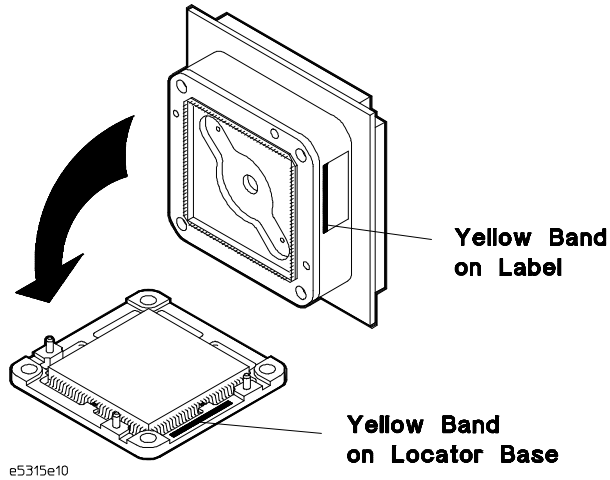

- 2 Press the adapter down on the pins until the adapter wires touch the package legs.

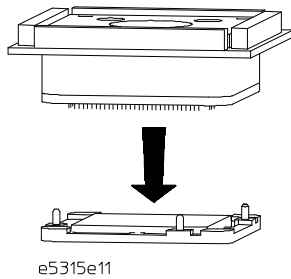

- 3 Use a magnifying glass and light to make sure that the wires align with the package legs around the entire package.

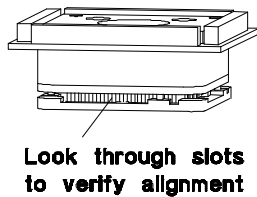

- 4 Ensure that every wire is directly above a leg, or not more than one-half of a wire diameter off to one side.

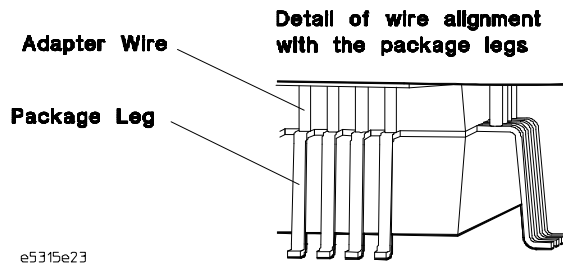

- 5 Insert the four corner mounting screws through the adapter and into the locator base corner inserts.

CAUTION

Optimum torque is 2.5 inch pounds. Excessive torque in tightening the four corner mounting screws can damage the screws. Insufficient torque can result in poor electrical contact to the target.

- 6 Turn the corner mounting screws until there is no slack. Then turn each screw a half turn, alternating between all four screws in a clockwise sequence until all screws are snug and the gap between the adapter and the locator base is closed. Check the alignment of the wires around the entire package again.

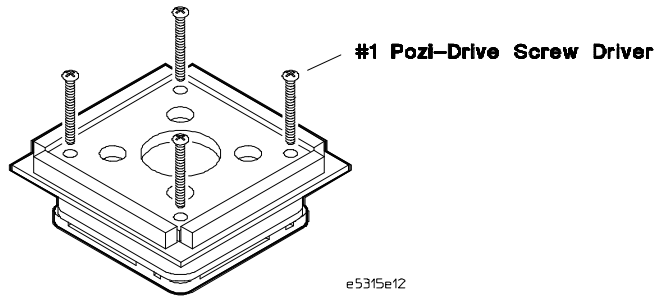

Attach the flexible or rigid adapters

Flexible and rigid adapters are available to connect to your logic analyzer or oscilloscope probe. Their characteristics are in the table below.

Table 2 - Characteristics of Optional Circuit Adapters

	HP E5316A 60-Pin Flexible Adapter	HP E5330A 60-Pin Rigid Adapter	HP E5333A 76-Pin Flexible Adapter
Used With	HP E5319A 160-Pin HP E5343A 184-Pin HP E5318A 208-Pin HP E5315A 240-Pin	HP E5319A 160-Pin HP E5343A 184-Pin HP E5318A 208-Pin HP E5315A 240-Pin	HP E5331A 304-Pin
Electrical Characteristics			
Operating Voltage	< 40 V (dc + Peak ac)	< 40 V (dc + Peak ac)	< 40 V (dc + Peak ac)
Operating Current	0.5 Amps Maximum	0.5 Amps Maximum	0.5 Amps Maximum
Insulation Resistance	> 100 M Ω	> 100 M Ω	> 100 M Ω
Model Parameters			
Pin-to-Ground Capacitance*	2.5 pF Typical First Row 3.5 pF Typical Second Row 4.5 pF Typical Third Row 5.5 pF Typical Fourth Row	2.0 pF Typical First Row 2.0 pF Typical Second Row 2.5 pF Typical Third Row 3.0 pF Typical Fourth Row	3.0 pF Typical First Row 3.5 pF Typical Second Row 4.5 pF Typical Third Row 5.0 pF Typical Fourth Row
Pin-to-Pin Capacitance	2 pF Typical	1.2 pF Typical	2 pF Typical
Self-Inductance	15 nH Typical First Row 25 nH Typical Second Row 35 nH Typical Third Row 45 nH Typical Fourth Row	10 nH Typical First Row 10 nH Typical Second Row 20 nH Typical Third Row 30 nH Typical Fourth Row	15 nH Typical First Row 25 nH Typical Second Row 35 nH Typical Third Row 45 nH Typical Fourth Row
Operating Bandwidth	350 MHz	350 MHz	350 MHz
Environmental Characteristics			
Operating Temperature	0 °C to 50 °C	0 °C to 50 °C	0 °C to 50 °C
Relative Humidity	75% Maximum	75% Maximum	75% Maximum

* Add these values to the value of the probe adapter assembly for your total capacitance.

Attaching flexible adapters

- 1 Determine the direction of the flexible adapter. This will depend on the location of your PQFP and any components that may obstruct the flexible adapter.
- 2 Plug the flexible adapter into a socket on top of the probe adapter assembly.

CAUTION

To prevent pin damage and ensure a proper connection, make sure the adapter pins are aligned and seated correctly in the socket.

- 3 Add the appropriate label. There are separate labels for 160-pin, 184-pin, 208-pin, 240-pin, and 304-pin. Use an outside adapter label for position A and an inside adapter label for position B.
- 4 Repeat the above steps for all sockets.
- 5 Connect the appropriate logic analyzer or oscilloscope probe to the adapter as indicated by the adapter label.

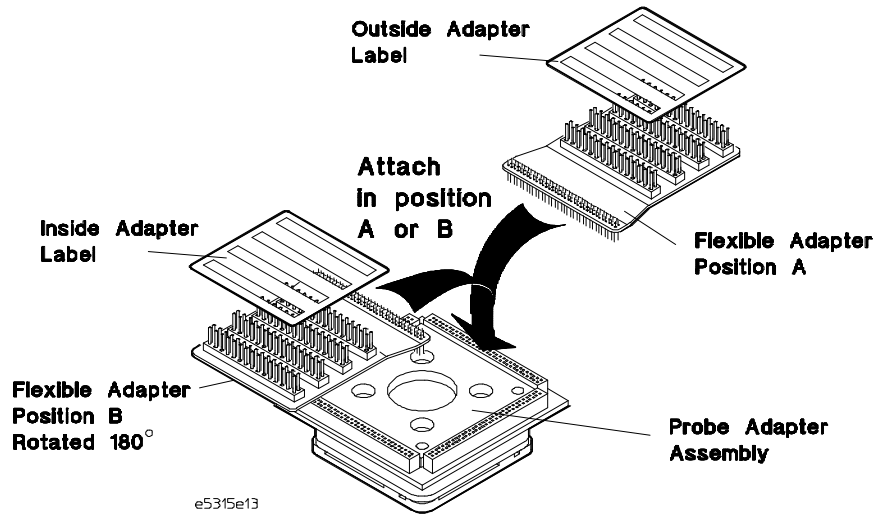

Attaching rigid adapters

Rigid adapters are available for the 160-pin, 184-pin, 208-pin, and 240-pin PQFP adapters.

- 1 Plug your rigid adapters into the sockets on the top of the probe adapter assembly as shown in the following illustration.

CAUTION

To prevent pin damage and ensure a proper connection, make sure the adapter pins are aligned and seated correctly in the socket.

- 2 Add the appropriate labels. There are separate labels for 160-pin, 184-pin, 208-pin, and 240-pin. Use an inside adapter label.
- 3 Connect the appropriate logic analyzer or oscilloscope probe to the adapter as indicated by the adapter label.

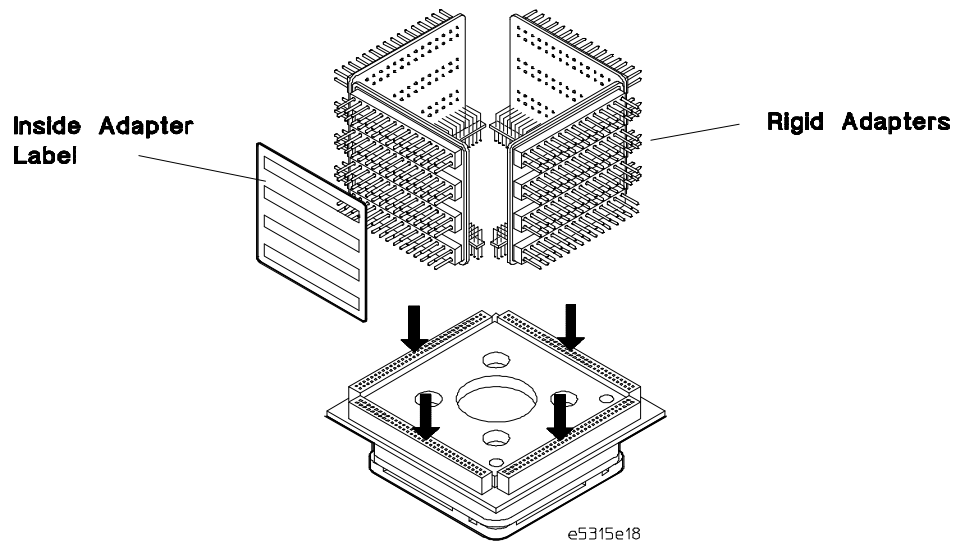

Additional parts

For probing additional ICs, order the following locator kits, flexible adapters, or rigid adapters.

Table 5 – Additional parts

	160-Pin Adapter	184-Pin Adapter	208-Pin Adapter	240-Pin Adapter	304-Pin Adapter
Flexible Adapter	E5316A	E5316A	E5316A	E5316A	E5333A
Rigid Adapter	E5330A	E5330A	E5330A	E5330A	Not applicable
Locator Kit - No Inserts	5042-1707	5042-1731	5042-1702	5041-9490	5052-1717
Locator Kit w/Inserts	5042-1706	5042-1730	5042-1701	5041-9489	5052-1716

Index

I

#2-56 inserts, 10
600-grit sandpaper, 4

A

adapter
assembly, 5 - 6
characteristics, 3
dimensions, 7 - 9
flexible, 18 - 20
grounding, 13
installing assembly, 16 - 17
labels, 19 - 20
PQFP at a glance, 2
rigid, 18 - 20
adapter wires, 16
adapters
installing flexible, 19
installing rigid, 20
additional parts, 21
adhesive, 12
alcohol, Isopropyl, 6
alignment of locator base, 11
attaching
flexible or rigid adapters, 18 - 20
locator base, 7 - 12

B

bandwidth, 3, 18
bent adapter wires, 5

C

capacitance, 18
capacitance between contacts, 3
Caution
damage or contamination, 4
damage to gold plating, 6
do not touch adapter wires, 5
handle probe adapter carefully, 15
installation is permanent, 11
optimum torque 2.5 inch pounds, 17
overly aggressive use of procedure, 6
power off, 4
prevent pin damage, 19 - 20
storing probe adapter, 5
use grounded wrist straps, 4, 7
characteristics, 3, 18
circuit adapters, 18

cleaning

probe adapter, 6
target IC, 4
color bands, 11, 16
combed guides, 11
contact resistance, 3
current, 3, 18

D

dimensions
160-pin adapter, 7
184-pin adapter, 8
208-pin adapter, 8
240-pin adapter, 9
304-pin adapter, 9

E

electrical characteristics, 3, 18
electrostatic discharge, 4, 7
environmental characteristics, 3, 18
establish grounding, 13 - 15
external mount kit, 10

F

flash removal, 11
flexible adapter
attaching, 18 - 20
part numbers, 21
flux removal, 4

G

glue, 12
ground ring, 13
grounding, 13 - 15
guides, on locator base, 11

H

high-pressure air, 4, 6
HP E5316A flexible adapter, 18
HP E5330A rigid adapter, 18
HP E5333A flexible adapter, 18
humidity, 3, 18

I

inductance, 3, 18
inserts, mounting on PC board, 10
install the probe adapter, 16 - 17
insulation resistance, 3, 18
introduction, 2
Isopropyl Alcohol, 6

L

labels, 19
locator base, 5, 7 - 12
combed guides, 11
with inserts, 10
without inserts, 10
locator kit
part numbers, 21

M

magnifying glass, 16
microscope, 4
mounting inserts on PC board, 10

O

overview, 2
oxide layer removal, 4

P

parameters
flexible and rigid adapters, 18
probe adapter, 3
part numbers
external mount kits, 10
flexible adapters, 21
locator kits, 21
rigid adapters, 21
pin guard, 5
pin numbers on probe adapter, 14
pin-to-ground capacitance, 18
pin-to-pin capacitance, 18
PQFP adapter, 2
prepare
adapter assembly, 5 - 6
target IC, 4
probe adapter assembly, 5
probing system, 2

R

relative humidity, 3, 18
removing
 oxide layers on target IC, 4
required tools for installation, 3
resistance, 3, 18
rigid adapters, 18 – 20
 part numbers, 21

S

self-inductance, 3, 18
socket
 legs, 13
 pin numbers, 13
solder, 15
storing probe adapter, 5

T

temperature, 3, 18
test alignment, 11
tools needed for installation, 3

V

voltage, 3, 18

W

Warning
 Flux remover use has hazards, 4
 Isopropyl Alcohol use has hazards, 6
 Read the Material Safety Data Sheet, 12

Y

yellow bands, 11, 16

Reproduction, adaptation, or translation without prior written permission is prohibited, except as allowed under the copyright laws.

Document Warranty

The information contained in this document is subject to change without notice.

Hewlett-Packard makes no warranty of any kind with regard to this material, including, but not limited to, the implied warranties of merchantability or fitness for a particular purpose.

Hewlett-Packard shall not be liable for errors contained herein or for damages in connection with the furnishing, performance, or use of this material.

Safety

This apparatus has been designed and tested in accordance with IEC Publication 348, Safety Requirements for Measuring Apparatus, and has been supplied in a safe condition. This is a Safety Class I instrument (provided with terminal for protective earthing). Before applying power, verify that the correct safety precautions are taken (see the following warnings). In addition, note the external markings on the instrument that are described under "Safety Symbols."

Warning

- Before turning on the instrument, you must connect the protective earth terminal of the instrument to the protective conductor of the (mains) power cord. The mains plug shall only be inserted in a socket outlet provided with a protective earth contact. You must not negate the protective action by using an extension cord (power cable) without a protective conductor (grounding). Grounding one conductor of a two-conductor outlet is not sufficient protection.
- Only fuses with the required rated current, voltage, and specified type (normal blow, time delay, etc.) should be used. Do not use repaired fuses or short-circuited fuseholders. To do so could cause a shock of fire hazard.

- Service instructions are for trained service personnel. To avoid dangerous electric shock, do not perform any service unless qualified to do so. Do not attempt internal service or adjustment unless another person, capable of rendering first aid and resuscitation, is present.
- If you energize this instrument by an auto transformer (for voltage reduction), make sure the common terminal is connected to the earth terminal of the power source.
- Whenever it is likely that the ground protection is impaired, you must make the instrument inoperative and secure it against any unintended operation.
- Do not operate the instrument in the presence of flammable gasses or fumes. Operation of any electrical instrument in such an environment constitutes a definite safety hazard.
- Do not install substitute parts or perform any unauthorized modification to the instrument.
- Capacitors inside the instrument may retain a charge even if the instrument is disconnected from its source of supply.
- Use caution when exposing or handling the CRT. Handling or replacing the CRT shall be done only by qualified maintenance personnel.

Safety Symbols



Instruction manual symbol: the product is marked with this symbol when it is necessary for you to refer to the instruction manual in order to protect against damage to the product.



Hazardous voltage symbol.



Earth terminal symbol: Used to indicate a circuit common connected to grounded chassis.

WARNING

The Warning sign denotes a hazard. It calls attention to a procedure, practice, or the like, which, if not correctly performed or adhered to, could result in personal injury. Do not proceed beyond a Warning sign until the indicated conditions are fully understood and met.

CAUTION

The Caution sign denotes a hazard. It calls attention to an operating procedure, practice, or the like, which, if not correctly performed or adhered to, could result in damage to or destruction of part or all of the product. Do not proceed beyond a Caution symbol until the indicated conditions are fully understood or met.

Product Warranty

This Hewlett-Packard product has a warranty against defects in material and workmanship for a period of one year from date of shipment. During the warranty period, Hewlett-Packard Company will, at its option, either repair or replace products that prove to be defective.

For warranty service or repair, this product must be returned to a service facility designated by Hewlett-Packard.

For products returned to Hewlett-Packard for warranty service, the Buyer shall prepay shipping charges to Hewlett-Packard and Hewlett-Packard shall pay shipping charges to return the product to the Buyer. However, the Buyer shall pay all shipping charges, duties, and taxes for products returned to Hewlett-Packard from another country.

Hewlett-Packard warrants that its software and firmware designated by Hewlett-Packard for use with an instrument will execute its programming instructions when properly installed on that instrument.

Hewlett-Packard does not warrant that the operation of the instrument software, or firmware will be uninterrupted or error free.

Limitation of Warranty

The foregoing warranty shall not apply to defects resulting from improper or inadequate maintenance by the Buyer, Buyer-supplied software or interfacing, unauthorized modification or misuse, operation outside of the environmental specifications for the product, or improper site preparation or maintenance.

No other warranty is expressed or implied. Hewlett-Packard specifically disclaims the implied warranties of merchantability or fitness for a particular purpose.

Exclusive Remedies

The remedies provided herein are the buyer's sole and exclusive remedies.

Hewlett-Packard shall not be liable for any direct, indirect, special, incidental, or consequential damages, whether based on contract, tort, or any other legal theory.

Assistance

Product maintenance agreements and other customer assistance agreements are available for Hewlett-Packard products.

For any assistance, contact your nearest Hewlett-Packard Sales Office.

Certification

Hewlett-Packard Company certifies that this product met its published specifications at the time of shipment from the factory. Hewlett-Packard further certifies that its calibration measurements are traceable to the United States National Institute of Standards and Technology, to the extent allowed by the Institute's calibration facility, and to the calibration facilities of other International Standards Organization members.

About this edition

This is the first edition of the *PQFP Adapter Installation Guide*.

Publication number
E5315-92006

Printed in USA.

March 1996

New editions are complete revisions of the manual. Update packages, which are issued between editions, contain additional and replacement pages to be merged into the manual by you. The dates on the title page change only when a new edition is published.

A software or firmware code may be printed before the date. This code indicates the version level of the software or firmware of this product at the time the manual or update was issued. Many product updates do not require manual changes; and, conversely, manual corrections may be done without accompanying product changes. Therefore, do not expect a one-to-one correspondence between product updates and manual updates.

The following list of pages gives the date of the current edition and of any changed pages to that edition.

All pages original edition